

Sequential Circuit Analysis

Tom Kelliher, CS 240

Apr. 7, 2010

1 Administrivia

Announcements

Xilinx assignment due Friday.

Exam on 4/14, covering 4.1–5.2, including material covered in class on addition.

Assignment

Read 5-5.

From Last Time

Flip-Flops and waveforms.

Outline

1. Reverse engineering a sequential circuit.
2. Input equations, state tables, and state diagrams.
3. Example problems.

Coming Up

Sequential circuit design.

2 Reverse Engineering Sequential Circuits

Analysis = reverse engineering.

One doesn't ordinarily do this, but doing so will help with sequential circuit design.

3 Input Equations, State Tables, and State Diagrams

Consider the following sequential circuit:

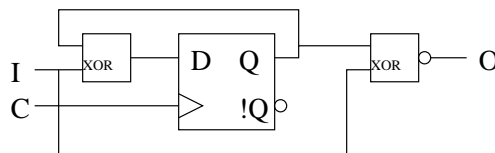

What does it do — high level?

What happens if we use !Q as the input to the XOR rather than Q?

Mealy (this circuit) vs. Moore machines.

3.1 Input Equations

What are the equations for O and D (input equation)?

Do these differ that much from anything we've already seen?

3.2 State Tables

State tables are similar to truth tables, with two additions:

1. Present state inputs — flip-flop outputs.
2. Next state outputs — derived from input equations for flip-flops.

Present State	I	Next State	O
0	0	0	1
0	1	1	0
1	0	1	0
1	1	0	1

3.3 State Diagrams

Conveys same information as state table, in a visual form.

State diagram for our example (Mealy):

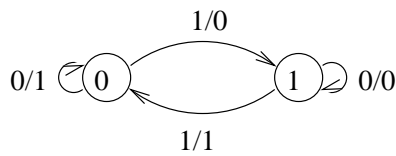

How do I read this?

Moore machine example:

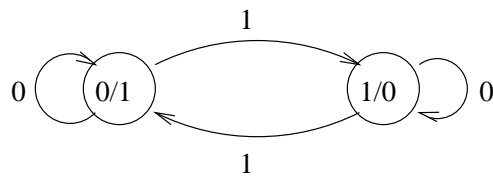

4 Example

Determine input and output equations, state table, and state diagram for this circuit:

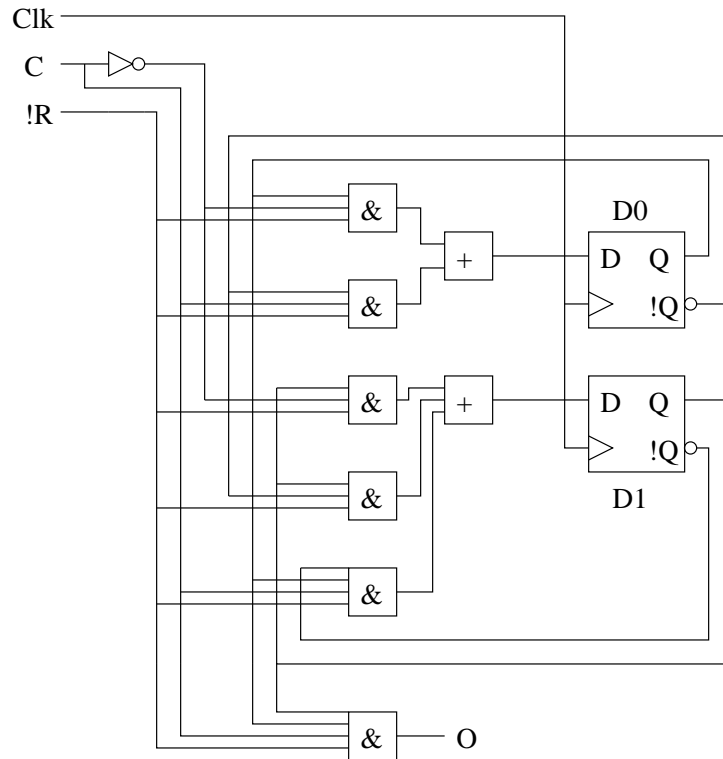

Is this Mealy or Moore?