

Pipelining a Datapath

Tom Kelliher, CS 240

Apr. 15, 2002

1 Administrivia

Announcements

Assignment

Read 6.3.

From Last Time

Overview of pipelining.

Outline

1. Pipelining: a pipelined datapath. Hazards.
2. Simple example: a single `lw`.

Coming Up

Pipelined control.

2 Pipelining

A pipelined datapath:

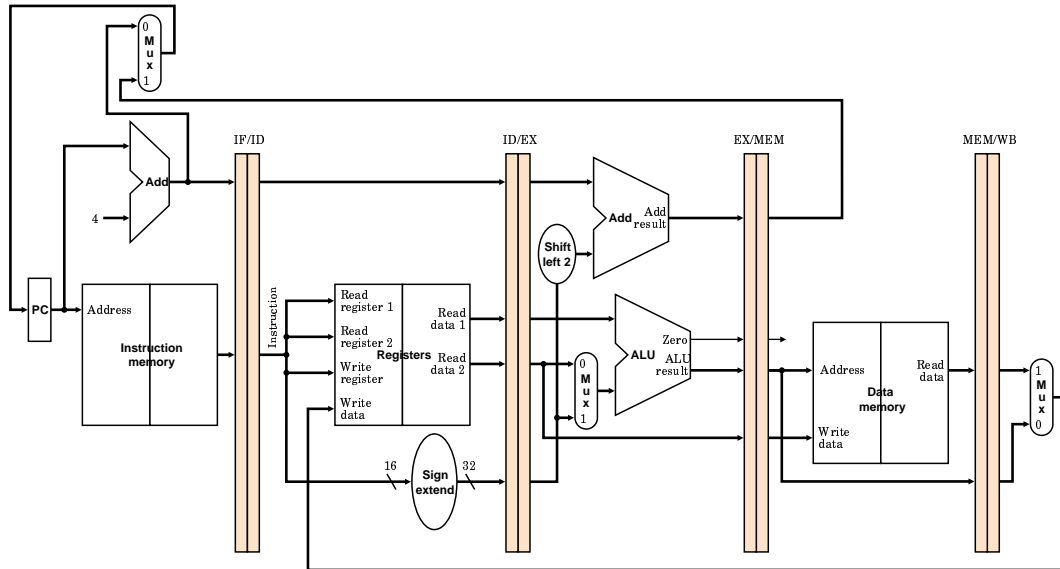

Consider four instructions: R-mode, a branch, LW, SW.

Observations:

1. Not a true pipeline: feedback.
2. How do we re-design control?

2.1 Hazards

1. Structural hazards.

Example: unified L1 cache/memory.

2. Control hazards. Consider the following example:

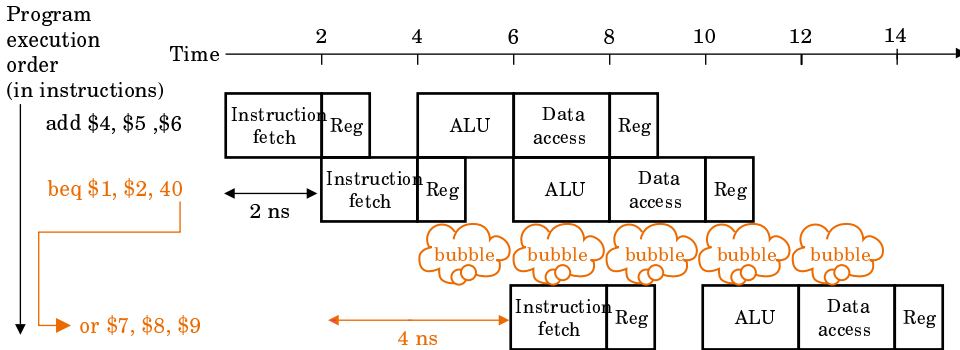
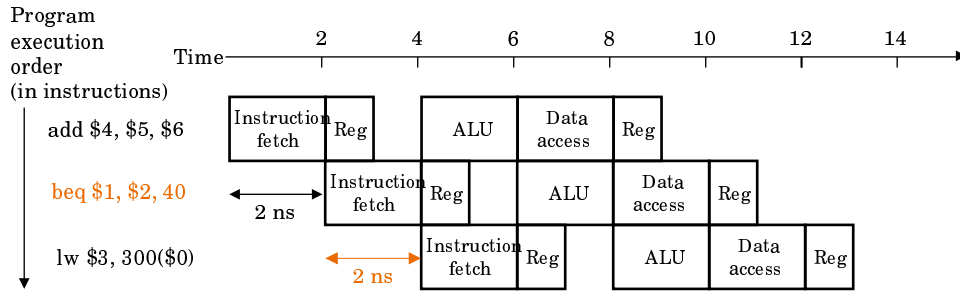

Solutions:

(a) Stall.

(b) Predict.

Static prediction. Truly static. Compile-time determined.

Dynamic prediction. Branch history tables. One-, two-bit counters.

(c) Delayed branch.

Assumes you know branch outcome early.

Code scheduling:

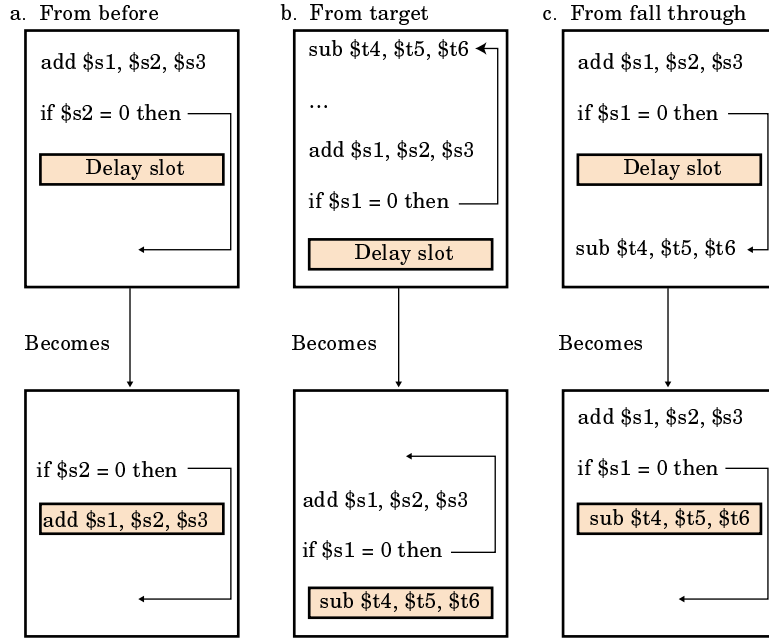

Consideration: deeper pipelines.

3. Data hazards.

Data not available when needed.

ALU example:

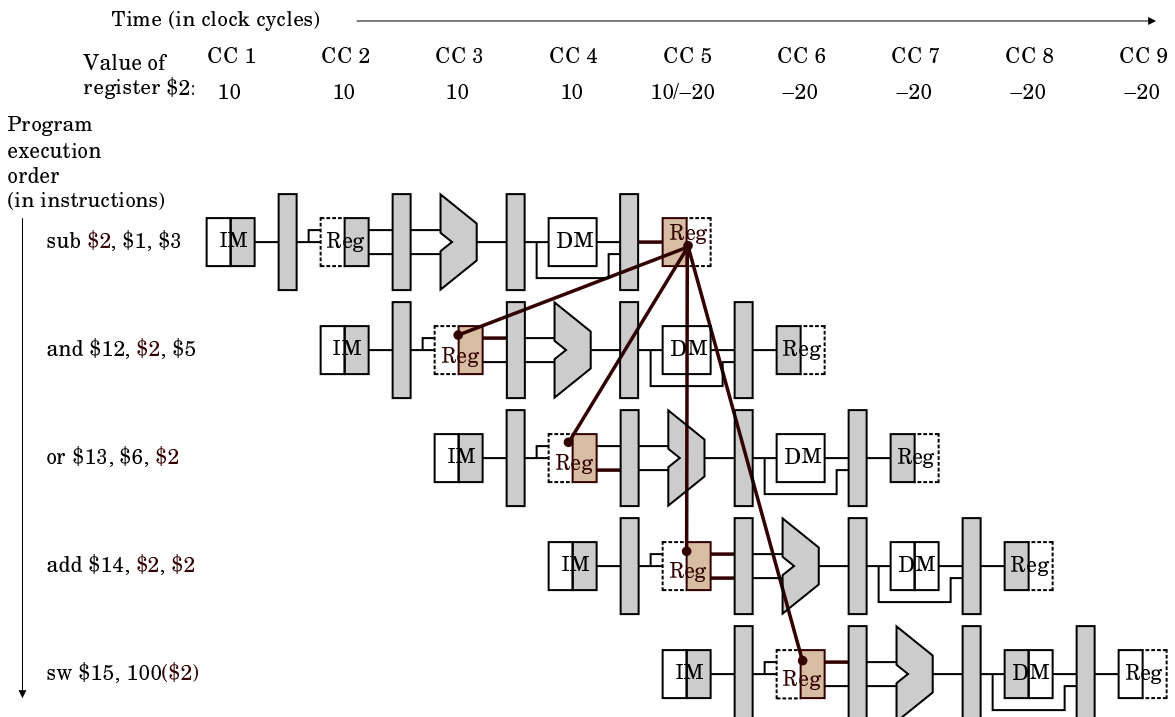

Fixed by forwarding.

Memory example:

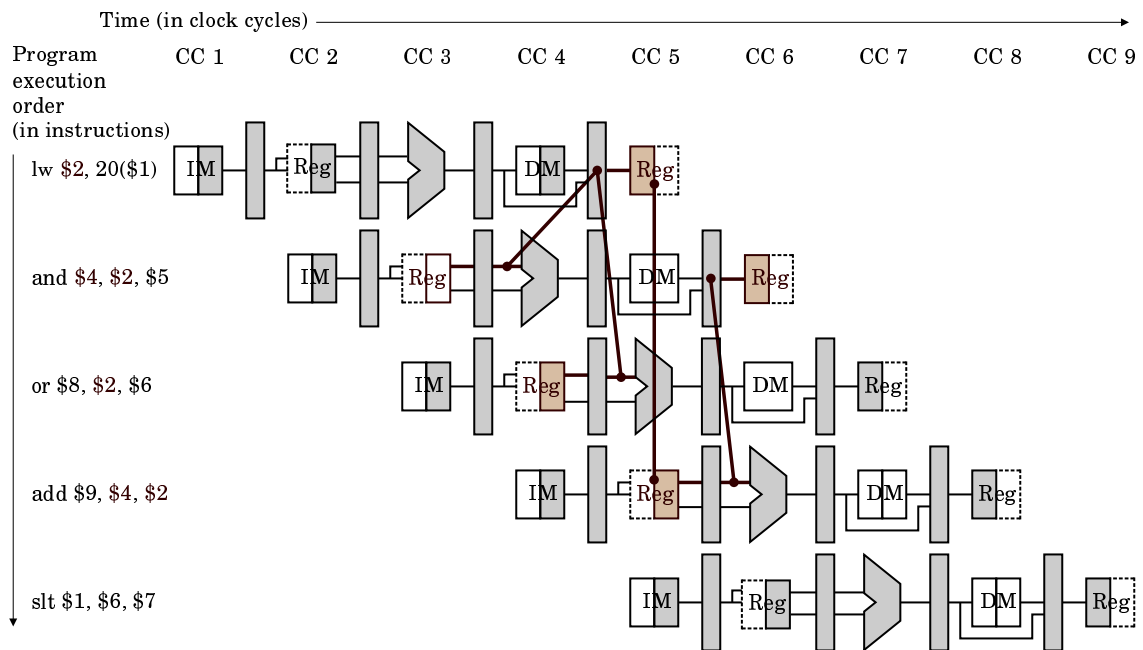

How can this be fixed?

2.2 Simple Example

Let's follow a lw. What's going on during each clock cycle?

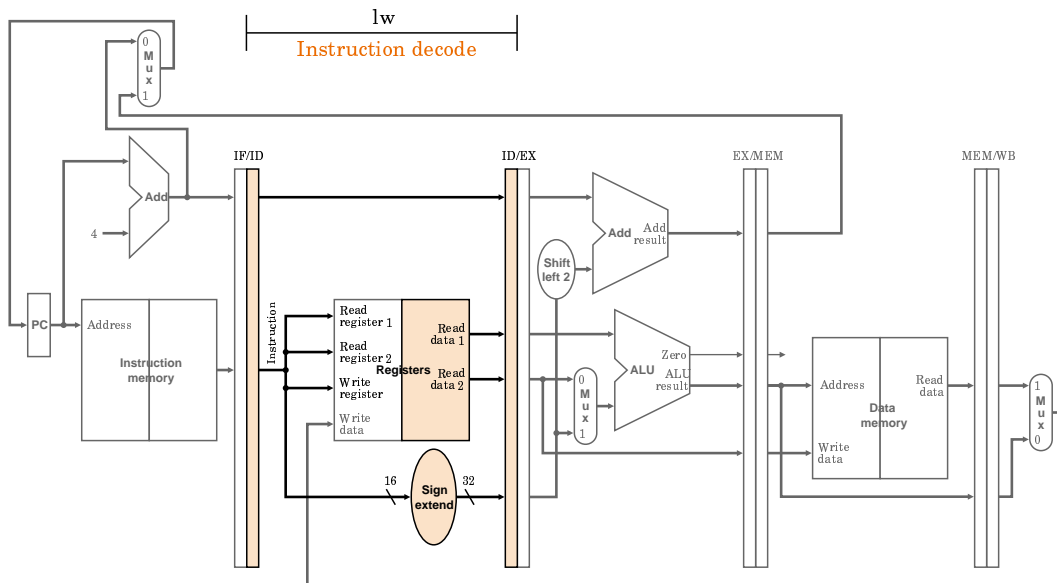
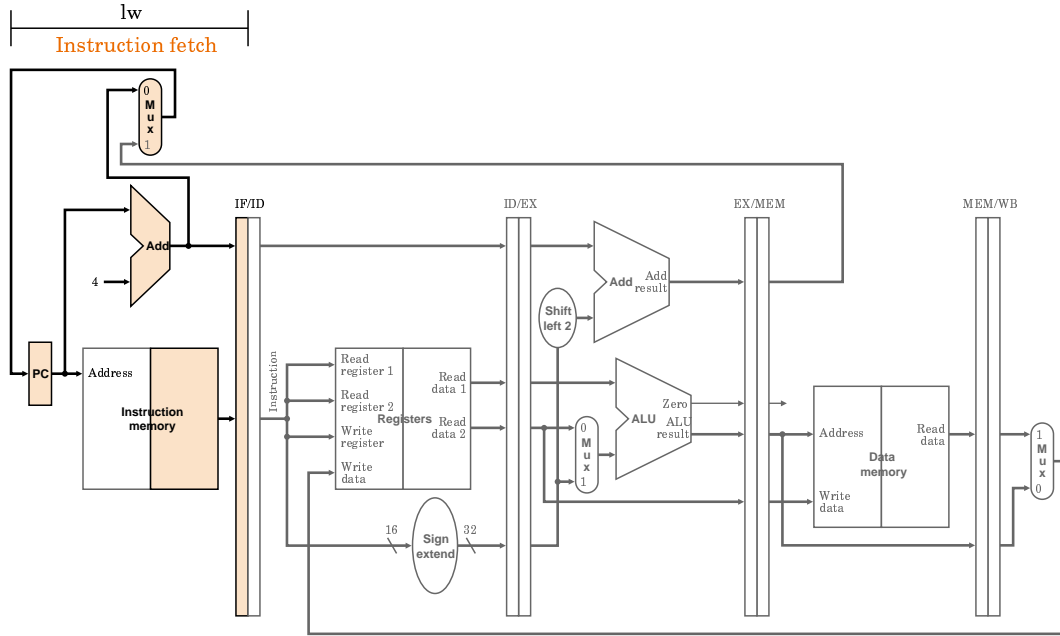

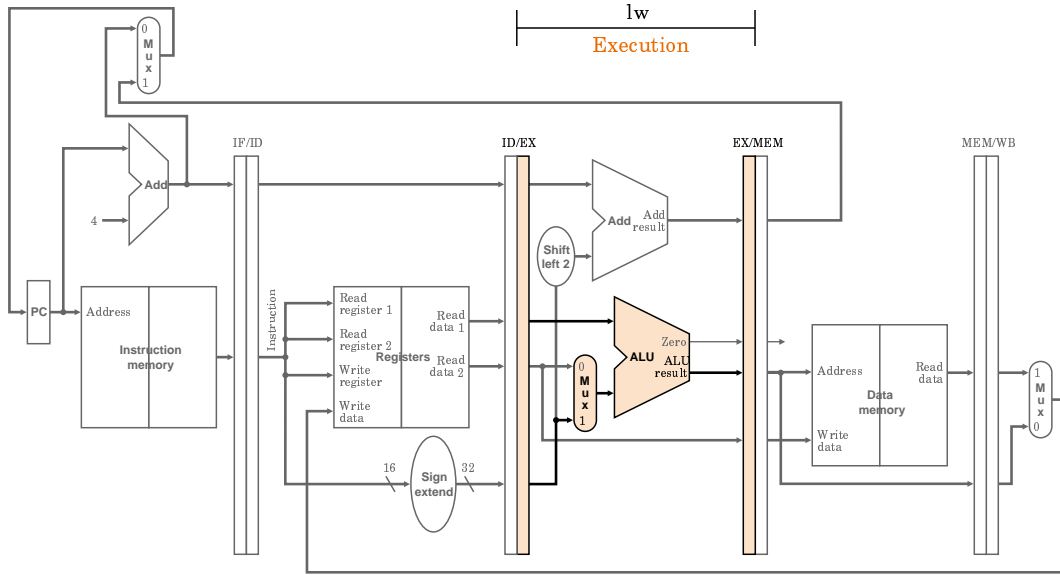

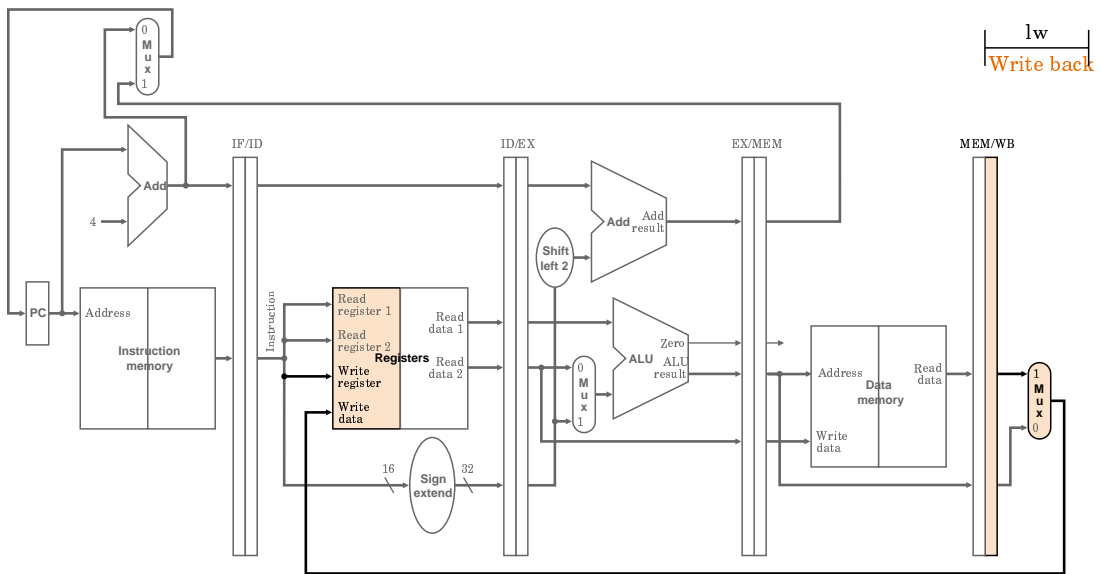
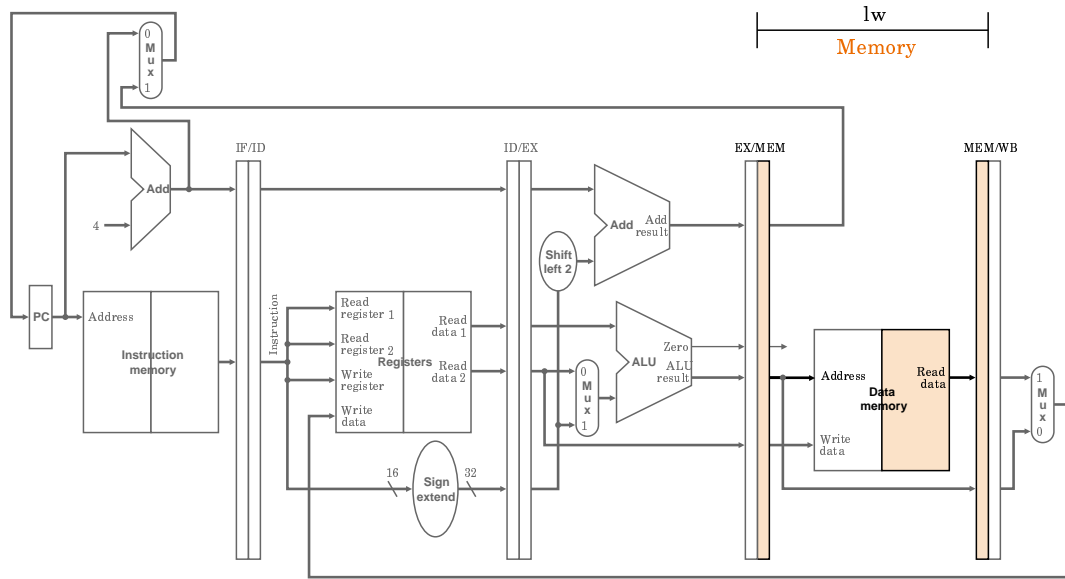

97108/Patterson
Figure 06.15