

# Decoders, Encoders, and Muxes, Oh My!

Tom Kelliher, CS 240

Feb. 22, 2010

## 1 Administrivia

### Announcements

Collect assignment.

### Assignment

Read 4.1–4.2. Review mostly; background for carry lookahead.

### From Last Time

Combinational design example.

### Outline

1. Decoders
2. Encoders
3. Muxes

## Coming Up

Lower bound for addition. Fast addition algorithms.

## 2 Decoders

Block diagram (diagram a 3-8 decoder):

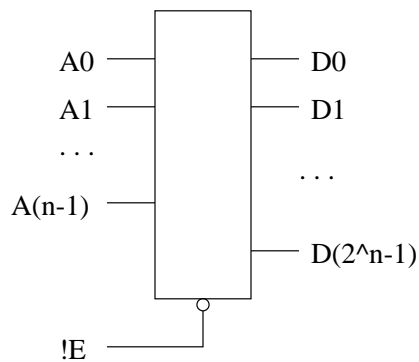

A circuit with  $n$  inputs. The inputs are interpreted as a binary number and used to select one of  $2^n$  output lines.

1. Most common use: Address decoders for RAMs and register files.
2. Decoder expansion example: design a 5-to-32 using 5 3-to-8 decoders.
3. Example use: Design a BCD to seven segment decoder using a 4 to 16 decoder and OR gates.

## 3 Encoders

Inverse of a decoder:  $2^n$  inputs;  $n$  outputs.

1. What happens if multiple inputs are high?

2. Most common uses: priority encoders for interrupt controllers; “hit” logic for caches.
3. Design example: Four input priority encoder with a “Valid” output.

## 4 Muxes

Used to select one of  $2^n$  inputs. One way switch.

Block diagram (draw a 4-1 mux):

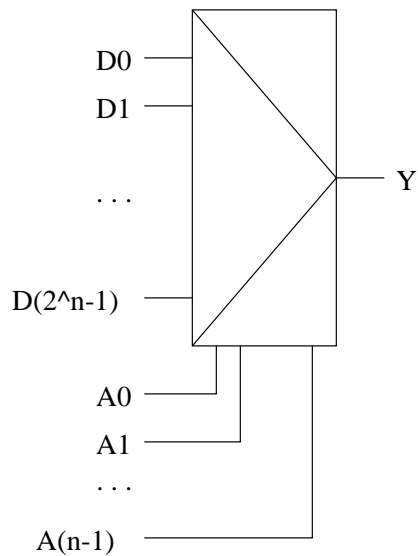

1. Most common uses: RAM, register file data selection circuits; Boolean function generators.
2. *What's a quad 2-1 mux?*
3. Design example: Implement a three input Boolean function using an 8-1 mux. No additional logic.

Four input Boolean function using an 8-1 mux and an inverter?

Five input Boolean function?