

Ultrasonic ranging module : HC-SR04

Specifications:

power supply :5V DC

quiescent current : <2mA

effectual angle: <15°

ranging distance : 2cm – 500 cm

resolution : 0.3 cm

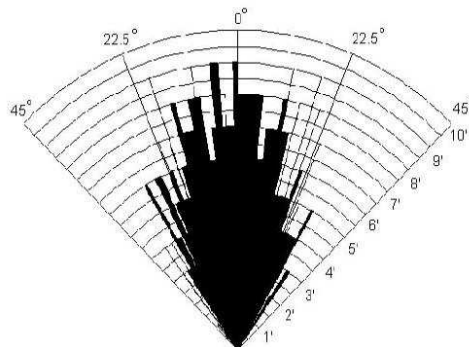
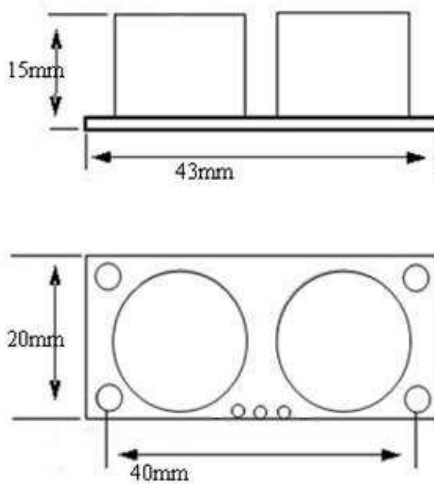
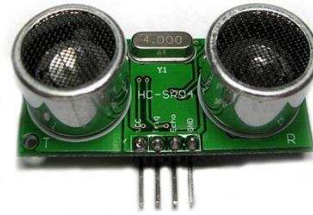

*Practical test of performance,
Best in 30 degree angle*

Sequence chart

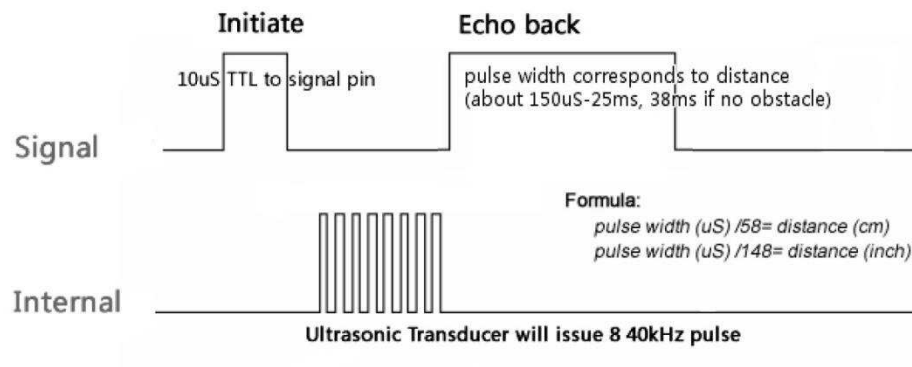

A short ultrasonic pulse is transmitted at the time 0, reflected by an object. The sensor receives this signal and converts it to an electric signal. The next pulse can be transmitted when the echo is faded away. This time period is called cycle period. The recommended cycle period should be no less than 50ms. If a 10µs width trigger pulse is sent to the signal pin, the Ultrasonic module will output eight 40kHz ultrasonic signal and detect the echo back. The measured distance is proportional to the echo pulse width and can be calculated by the formula above. If no obstacle is detected, the output pin will give a 38ms high level signal.

Library:

<http://iteadstudio.com/store/images/produce/Robot/HCSR04/Ultrasonic.rar>



Ultrasonic Ranging Module HC - SR04

Product features:

Ultrasonic ranging module HC - SR04 provides 2cm - 400cm non-contact measurement function, the ranging accuracy can reach to 3mm. The modules includes ultrasonic transmitters, receiver and control circuit. The basic principle of work:

- (1) Using IO trigger for at least 10us high level signal,
- (2) The Module automatically sends eight 40 kHz and detect whether there is a pulse signal back.
- (3) IF the signal back, through high level , time of high output IO duration is the time from sending ultrasonic to returning.

Test distance = (high level time×velocity of sound (340M/S) / 2,

Wire connecting direct as following:

- 5V Supply
- Trigger Pulse Input
- Echo Pulse Output
- 0V Ground

Electric Parameter

Working Voltage	DC 5 V
Working Current	15mA
Working Frequency	40Hz
Max Range	4m
Min Range	2cm
MeasuringAngle	15 degree
Trigger Input Signal	10uS TTL pulse
Echo Output Signal	Input TTL lever signal and the range in proportion
Dimension	45*20*15mm



Timing diagram

The Timing diagram is shown below. You only need to supply a short 10uS pulse to the trigger input to start the ranging, and then the module will send out an 8 cycle burst of ultrasound at 40 kHz and raise its echo. The Echo is a distance object that is pulse width and the range in proportion. You can calculate the range through the time interval between sending trigger signal and receiving echo signal. Formula: $\mu\text{S} / 58 = \text{centimeters}$ or $\mu\text{S} / 148 = \text{inch}$; or: the range = high level time * velocity (340M/S) / 2; we suggest to use over 60ms measurement cycle, in order to prevent trigger signal to the echo signal.

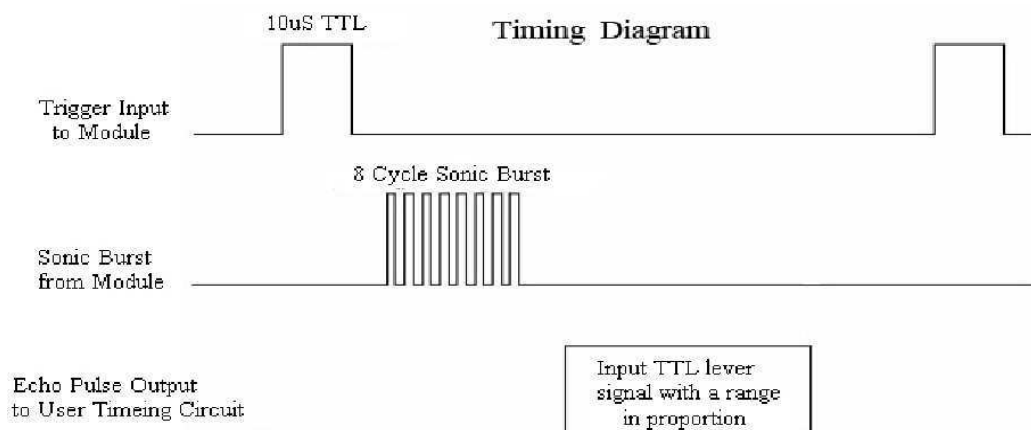

Attention:

- The module is not suggested to connect directly to electric, if connected electric, the GND terminal should be connected the module first, otherwise, it will affect the normal work of the module.
- When tested objects, the range of area is not less than 0.5 square meters and the plane requests as smooth as possible, otherwise ,it will affect the results of measuring.

www.ElecFreaks.com

