

Memory: ROM and RAM

Tom Kelliher, CS 220

Nov. 17, 2003

1 Administrivia

Announcements

Homework due Wednesday!

Assignment

Read 6.2–4.

From Last Time

Exam.

Outline

1. Introduction.
2. ROM.
3. RAM.

Coming Up

Details on RAM.

2 Introduction

1. What is memory?
2. Volatile vs. non-volatile.
3. RAM characteristics: speed, density, power.
4. Memory hierarchy: registers, cache, main memory, etc.
5. General structure:

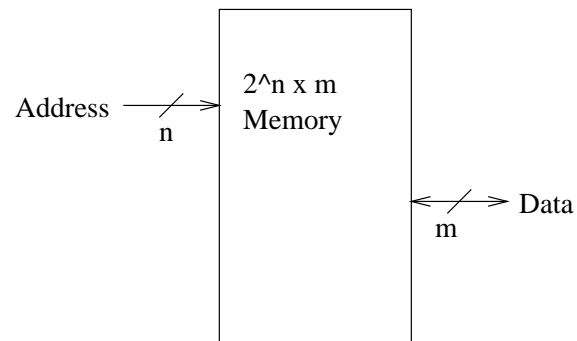

3 ROM

1. Technologies: PROM, EPROM (UV), EEPROM, EAPROM.
2. Where do you find ROM in a PC?
3. Structure of a ROM:

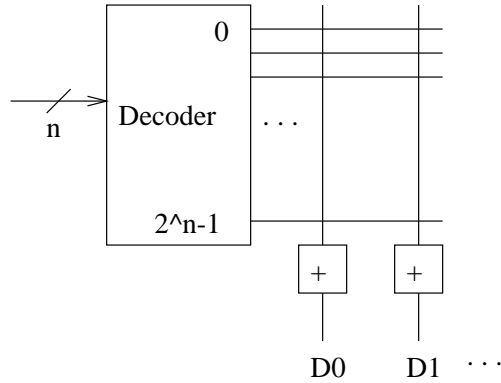

Minterms, fusible links.

4. Usage: program storage, generation of combinational functions.

How do you use for combinational functions?

4 RAM

1. Additional inputs: !Enable, Read!/Write
2. Static RAM: latches, inverter pair.

Used for caches. Fast. Not dense. High power.

3. Dynamic RAM: stored charge on a capacitor.

(a) Leakage, refresh.

(b) Used for main memory. Slow. Dense. Low power.

(c) Sizes. I/O pin limitations. Solutions: one bit wide, address multiplexing. 2-D structure.

(d) Additional inputs: RAS, CAS.

4. Read/Write sequences.

Write strobe with respect to the clock signal. Importance of address bus settling before write asserts.